

VISION

FANUC 0 - M / 21 - M

- **Fräsen**
- **Milling**
- **Fraisage**
- **Fresar**

Ref. Nr.: VS 9973

Hersteller:

EMCO MAIER Gesellschaft m.b.H.- P.O.Box 131- A-5400 Hallein/Austria- Tel.(06245) 891-0 Fax (06245) 86965

INHALTSVERZEICHNIS

Folie Nr.	Thema
1, 1a	Steuerungslayout Fanuc 0 - M, 21 - M
2	Bezugspunkte (M,A,W,R) und Koordinatensystem - Grundbild
3	Bezugspunkte am Werkzeugsystem (N, P); Darstellung Referenzieren.
4	Bezugspunkte: Symbole und Kurzzeichen
5	Nullpunktverschiebung (NPV) Offset Nr.00 - Grundbild
6	G54 - G59 Additive NPV Nr. 01-06 - Grundbild
7	Kombination Offset und Additive NPV - Grundbild
8	Koordinatensystem zu NPV-Darstellung
9	Werkzeugkorrektur-Daten
10	G00 Eilgang
11	G01 Linearinterpolation
12	G02 Kreisinterpolation im Uhrzeigersinn
13	G03 Kreisinterpolation im Gegenuhrzeigersinn
14	Kreisinterpolation mit Mittelpunktskordinaten I, K
15	Einfügen von Radien "R" und Fasen "C"
16	G04 Verweilzeit
17	G16 Polarkoordinaten
18	G17 - G19 Ebenenwahl
19	G33 Gewindeschneiden
20	G40 - G42 Fräserradiuskompensation
21	G51 Maßstabsfaktor
22	G51 Spiegeln Kontur
23	G09, G61, G64 Genauhalt, Schneidmodus
24	G73, G83 Bohrzyklen Spanbruch / Ausheben
25	G74, G84 Gewindebohrzyklen Links / Rechts
26	G81, G82 Bohrzyklen ohne / mit Verweilzeit
27	G85, G89 Ausreibbohrzyklen ohne / mit Verweilzeit
28	G86, G88 Bohrzyklen mit Spindelhalt / Programmhalt
29	G90, G91 Absolut- / Inkrementalwertprogrammierung
30	G98, G99 Rückzug auf Startebene / Rückzugebene
31	M98, M99 Unterprogrammtechnik

TABLE OF CONTENTS

Slide No.	Subject
1, 1a	Layout Fanuc 0 - M, 21 - M
2	Reference points (M,A,W,R) and coordinate system
3	Reference points of tool system (N,P); approaching reference point
4	Symbols and signs of reference points
5	Zero shift offset No.00
6	G54 - G59 Zero shift additive No.01-06
7	Combination zero offset and additive offset
8	Coordinate system to zero shift presentation
9	Tool offsets
10	G00 Rapid traverse
11	G01 Linear interpolation
12	G02 Circular interpolation, clockwise
13	G03 Circular interpolation, counter-clockwise
14	Circular interpolation with parameters I, K
15	Insertion of radii "R" and chamfers "C"
16	G04 Dwell
17	G16 Polar coordinates
18	G17 - G19 Plane selection
19	G33 Thread cutting
20	G40 - G42 Cutter radius compensation (CRC)
21	G51 Scale modification
22	G51 Mirroring contour
23	G09, G61, G64 Precise stop, continuous path
24	G73, G83 Drilling cycles chip breaking / swarf removal
25	G74, G84 Tapping cycles left / right
26	G81, G82 Drilling cycles without / with dwell
27	G85, G89 Reaming cycles without / with dwell
28	G86, G88 Drilling cycles with spindle stop / programme stop
29	G90, G91 Absolute / Incremental programming
30	G98, G99 Withdrawal to starting plane / withdrawal plane
31	M98, M99 Subroutine technics

TABLE DE MATIERES

Transparent Nr.	Thèmes
1, 1a	Pupitre de commande Fanuc 0 - M, 21 - M
2	Points de référence (M,A,W,R) et système de coordonnées
3	Points de référence d'outillage (N, P); accostage du point de référence.
4	Symboles graphiques des points de référence
5	Décalage d'origine No.00
6	G54 - G59 Décalages d'origine additif
7	Combinaison décalage d'origine et décalage additif
8	Système de coordonnées pour présenter la décalage d'origine
9	Correcteur d'outils
10	G00 Vitesse rapide
11	G01 Interpolation linéaire
12	G02 Interpolation circulaire en sens horaire
13	G03 Interpolation circulaire en sens antihoraire
14	Interpolation circulaire avec paramètres d'interpolation I, K
15	Insérer des rayons "R" et chanfreins "C"
16	G04 Temporisation
17	G16 Coordonnées polaires
18	G17 - G19 Sélection du plan
19	G33 Filetage
20	G40 - G42 Compensation du rayon de plaquette (CRP)
21	G51 Changement d'échelle
22	G51 Contour miroiter
23	G09, G61, G64 Arrêt précis fin, fonction en contournage
24	G73, G83 Cycles de perçage brise copeaux / extrait copeaux
25	G74, G84 Cycles de taraudage gauche / droit
26	G81, G82 Cycles de perçage sans / avec temporisation
27	G85, G89 Cycles d'alésage sans / avec temporisation
28	G86, G88 Cycles de perçage arrêt broche / arrêt programme
29	G90, G91 Programmation en valeurs absolues / incrementielles
30	G98, G99 Retrait sur plan de positionnement / de référence
31	M98, M99 Technique de sous-programmes

CONTENIDO

Hoja no.	Tema
1, 1a	Pupitre de mando Fanuc 0 - M, 21 - M
2	Puntos de referencia (M,A,W,R) y sistema de coordenadas
3	Puntos de referencia en el sistema de herramientas (N,P); acercarse al puntos de referencia R
4	Simbolos y abreviaturas para los puntos de referencia
5	Decalaje del origen básico no.00
6	G54 -G59 Decalaje del origen no.01-06
7	Combinación de decalaje del origen no.00 con no.01-06
8	Sistema de coordenadas para representación de decalaje
9	Datos de corrección de herramienta
10	G00 Desplazamiento rápido
11	G01 Interpolación lineal
12	G02 Interpolación circular en sentido horario
13	G03 Interpolación circular en sentido antihorario
14	Interpolación circular con parámetros de interpolación I, K
15	Introducción de radios "R" y chaflanes "C"
16	G04 Tiempo de parada
17	G16 Coordenadas polares
18	G17 - G19 Selección de plano
19	G33 Roscado
20	G40 - G42 Compensación del radio de corte (CRC)
21	G51 Cambio de escalas
22	G51 Reflejar contorno
23	G09, G61, G64 Parada precisa fina, servicio de contorneado
24	G73, G83 Ciclo de taladrado rotura viruta / quitar viruta
25	G74, G84 Ciclo de roscado a la izquierda / a la derecha
26	G81, G82 Ciclos de taladrados sin / con tiempo de parada
27	G85, G89 Ciclos de escariados sin / con tiempo de parada
28	G86, G88 Ciclos de taladrados con parada de cabezal / de programa
29	G90, G91 Introducción de cotas absolutas / incrementales
30	G98, G99 Regreso a nivel de comienzo / de regreso
31	M98, M99 Técnica de subprogramas

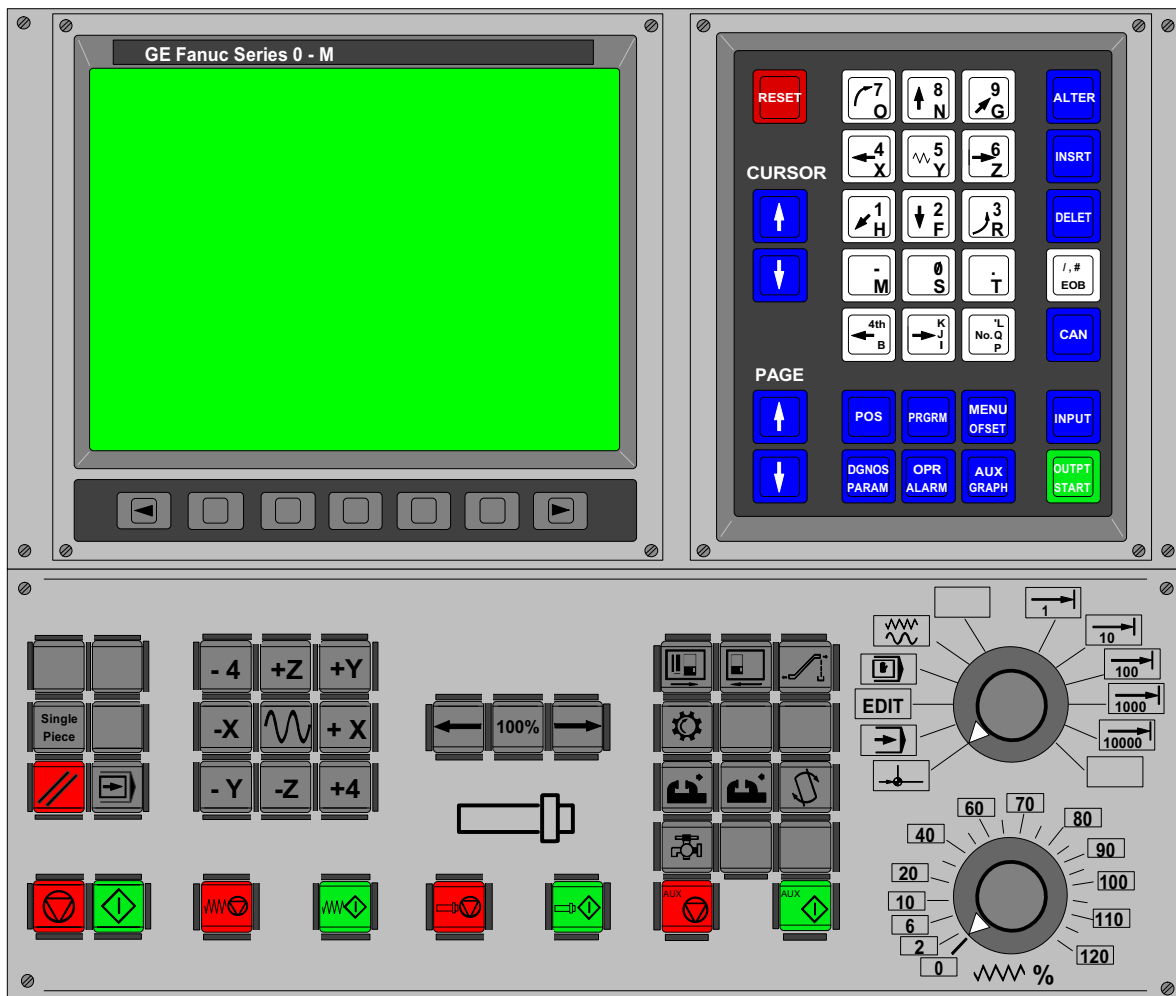

21-M

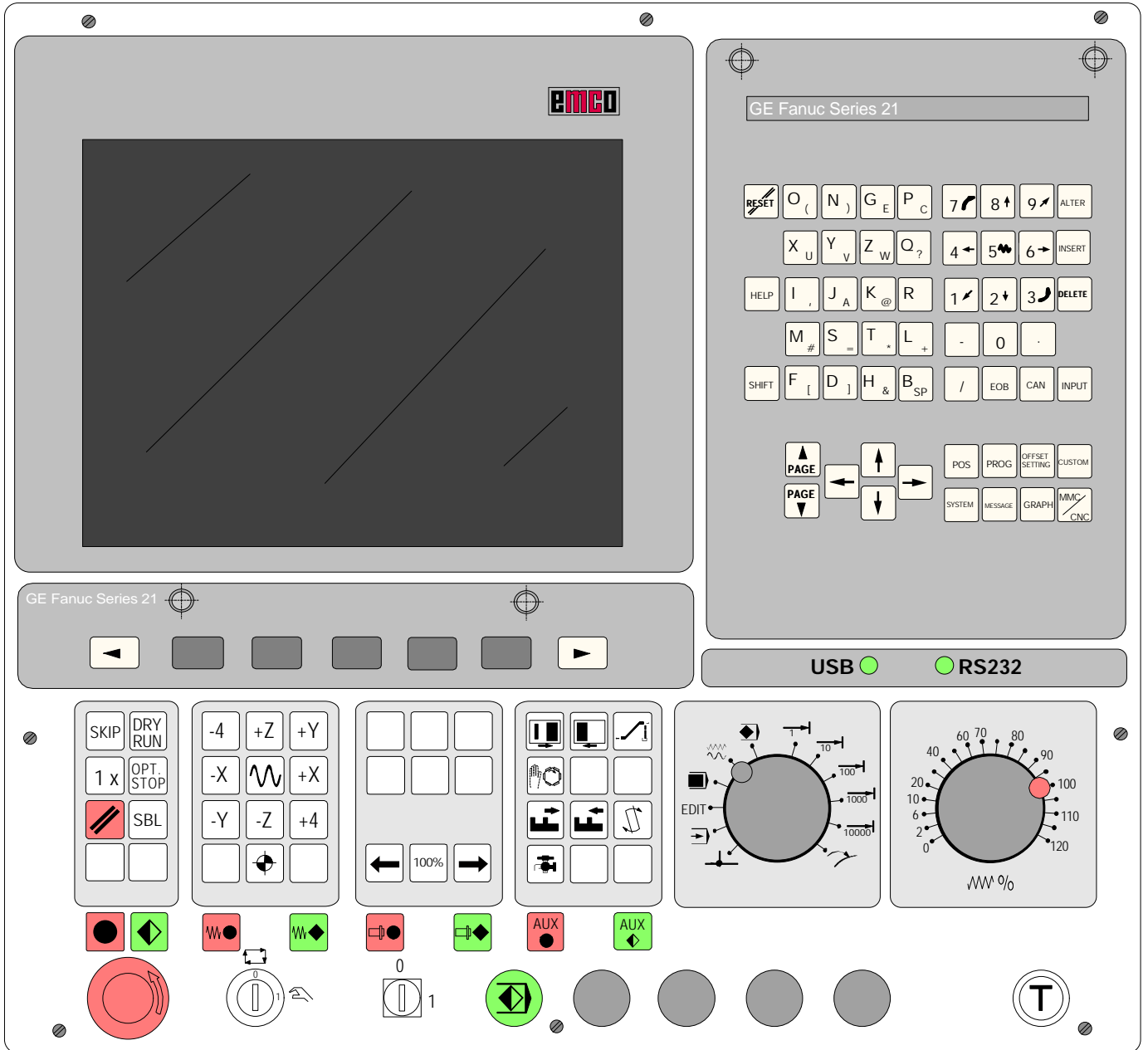

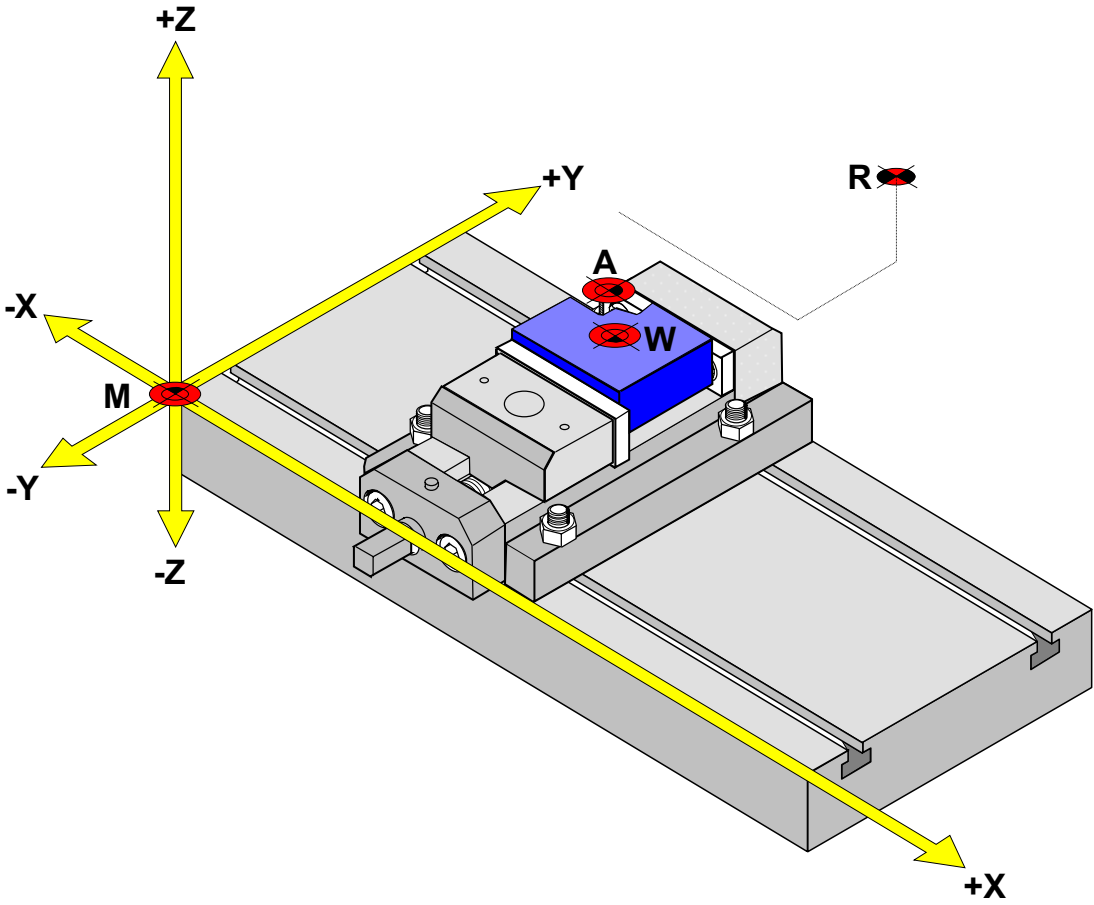

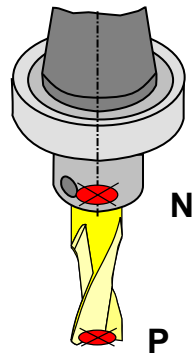



M

Maschinennullpunkt
Machine zero point
Origine de la machine
Punto cero de la máquina



A

Anschlag-Punkt
Dead stop point
Point d'arrêt du pièce
Punto de tope



W

Werkstücknullpunkt
Workpiece zero point
Origine de la pièce
Punto cero de la pieza



R

Referenzpunkt
Reference point
Référence de la machine
Punto de referencia



T

Werkzeugträger-Bezugspunkt
Toolholder reference point
Référence des portes-outils
Punto de referencia del portaherramientas



N

Werkzeugaufnahme-Bezugspunkt
Tool mount reference point
Référence du système d'outillage
Punto de referencia para toma de herramienta



P

Werkzeugpunkt
Cutterpoint
Point tranchant d'outil
Punta de herramienta

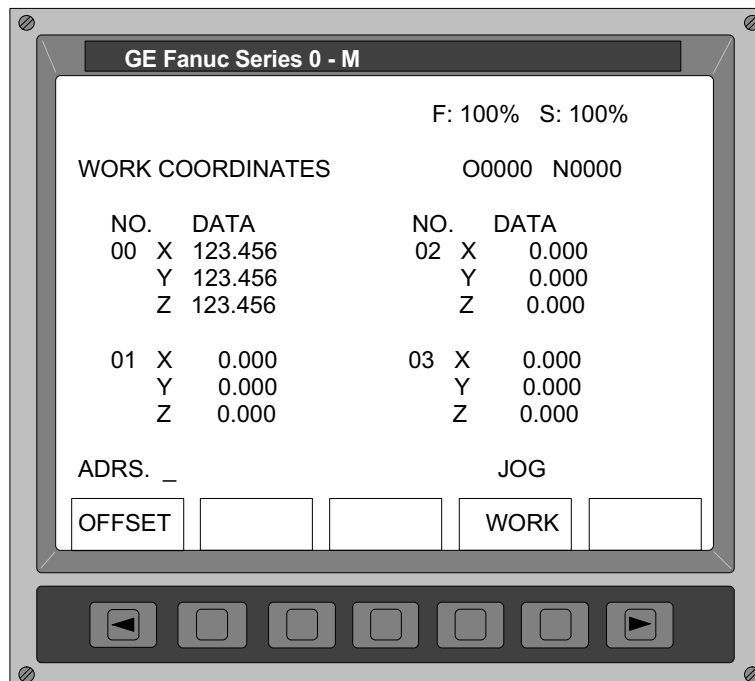
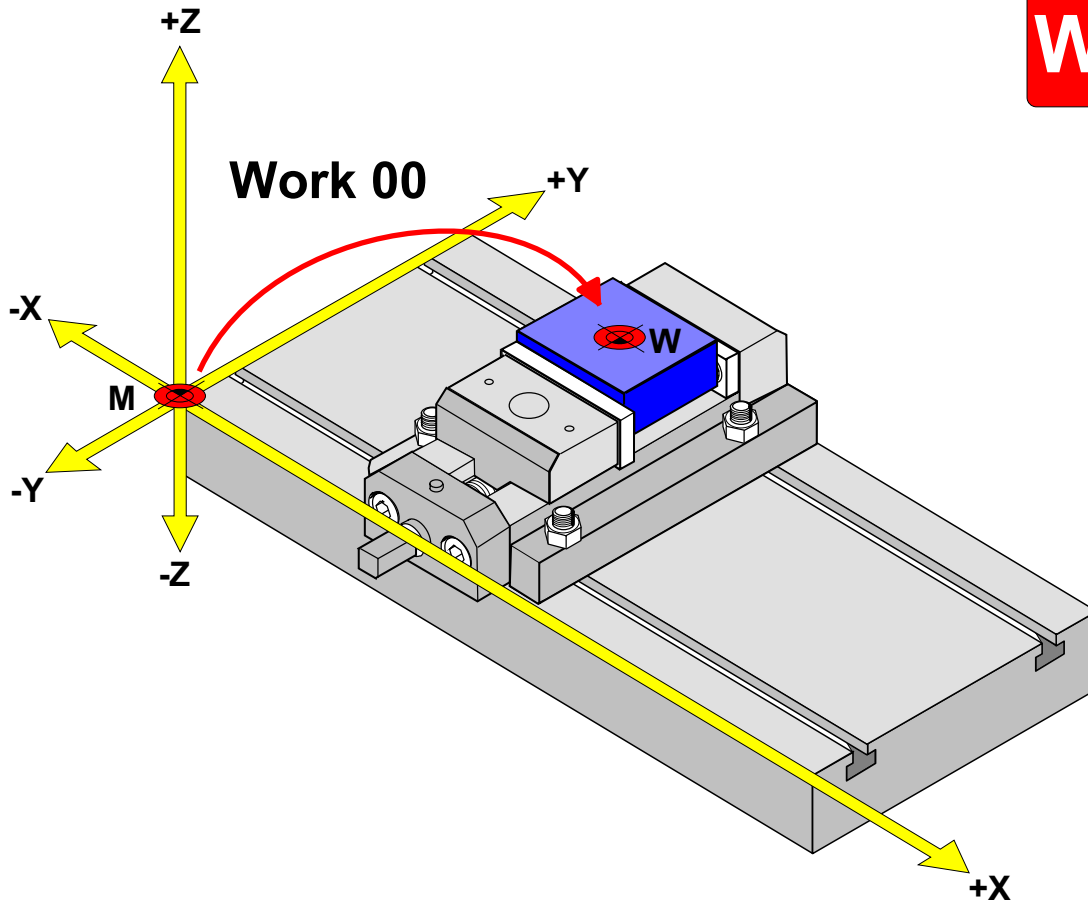

G54 - G59

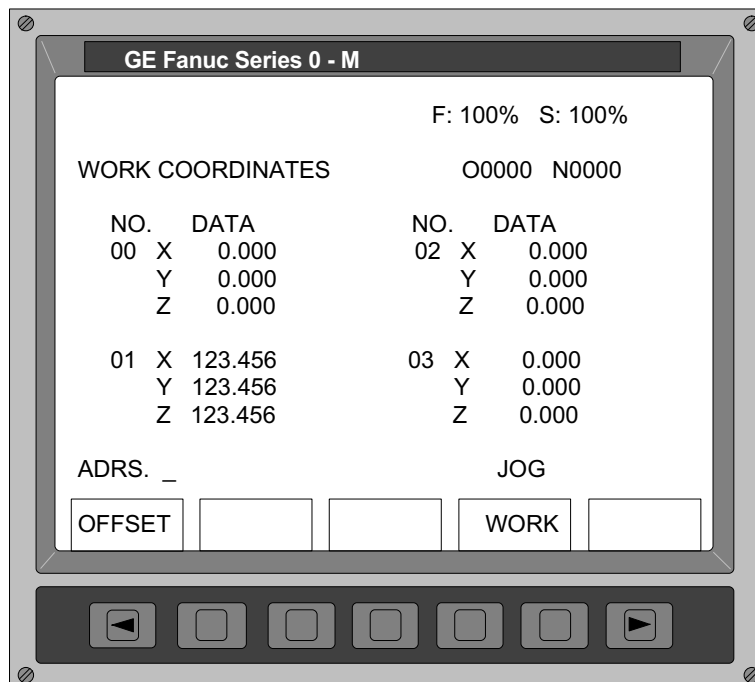
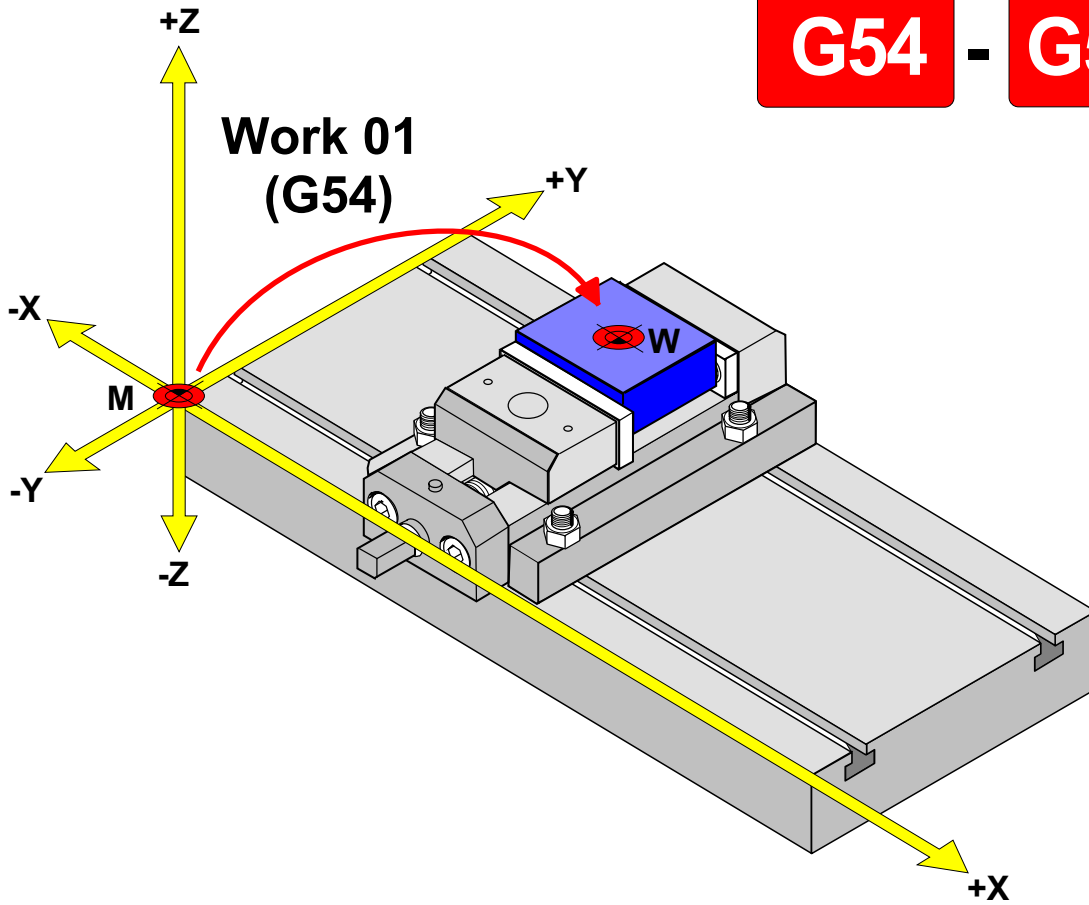

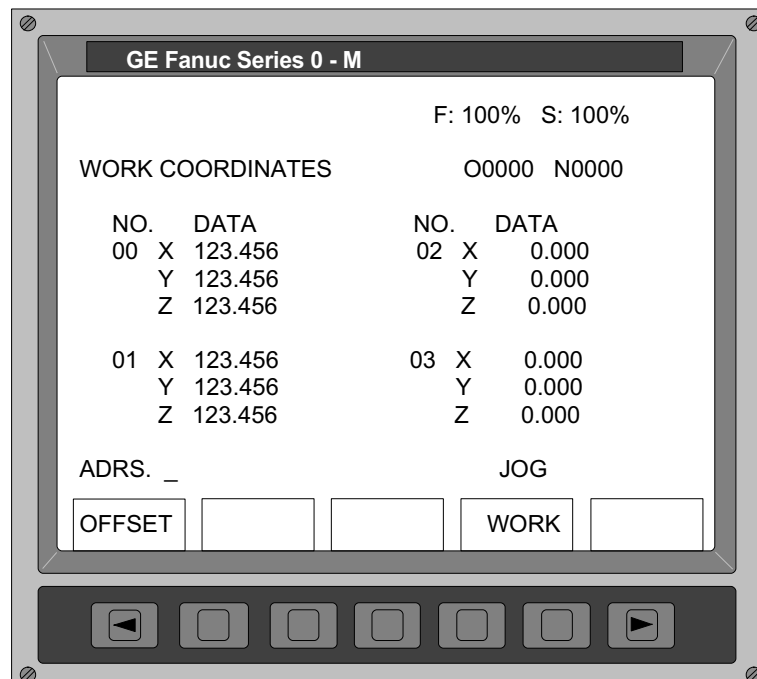
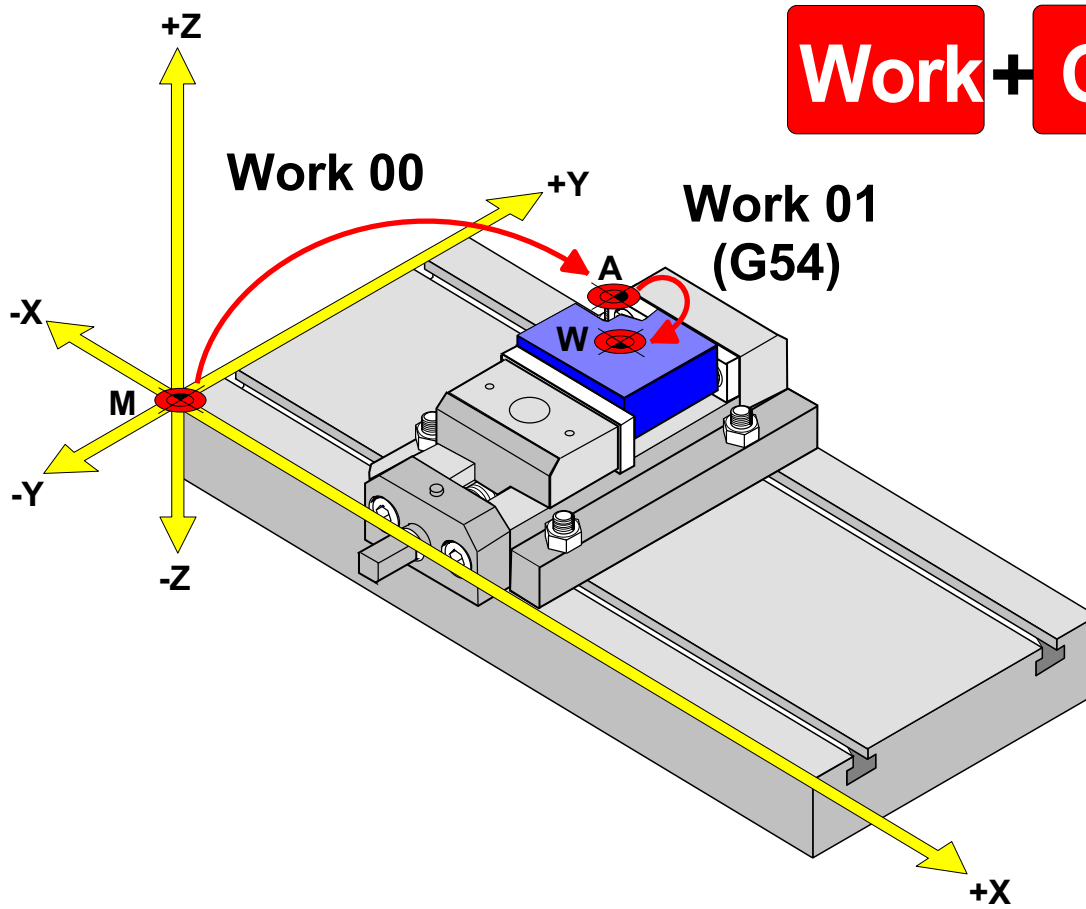

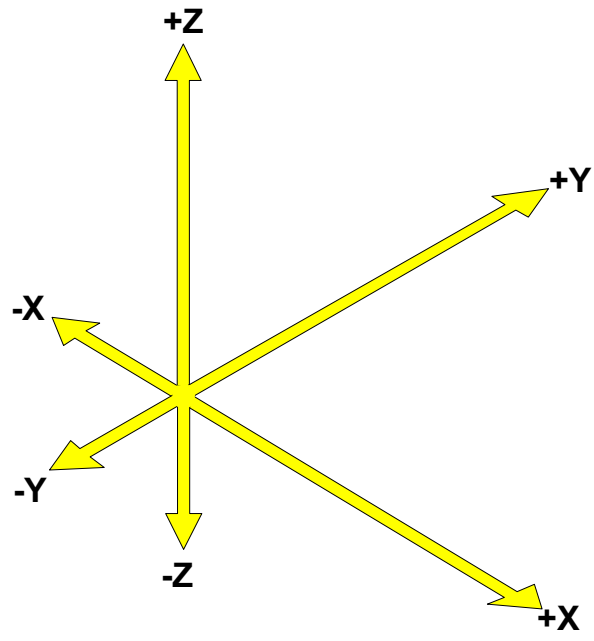

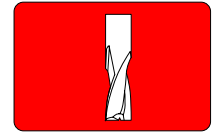

T1 G43 H1

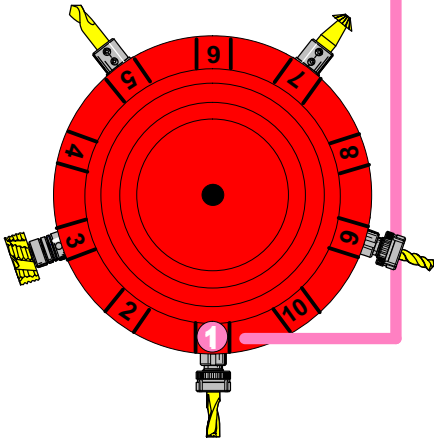

GE Fanuc Series 0 - M

OFFSET			
NO.	DATA	NO.	DATA
001	12.345	009	0.000
002	0.000	010	0.000
003	0.000	011	0.000
004	0.000	012	1.234
005	0.000	013	0.000
...

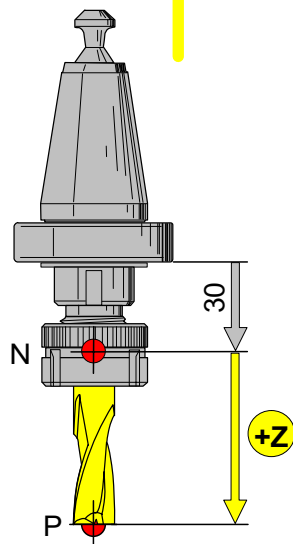

**G41 H12
G42 H12**

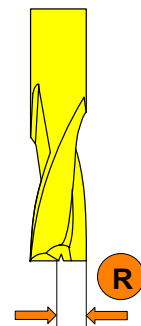

G00

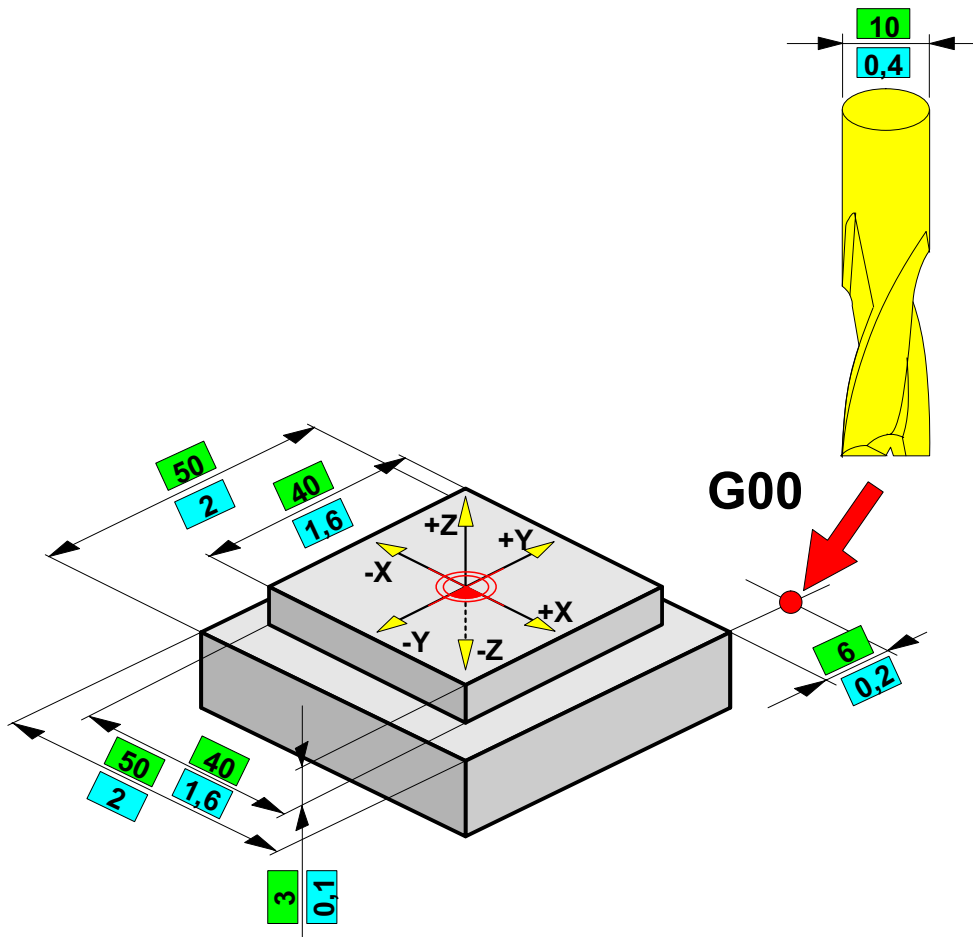

N1234 G00 X25 Y31 Z-3 LF mm

N1234 G00 X1 Y1.2 Z-0.1 LF inch

G01

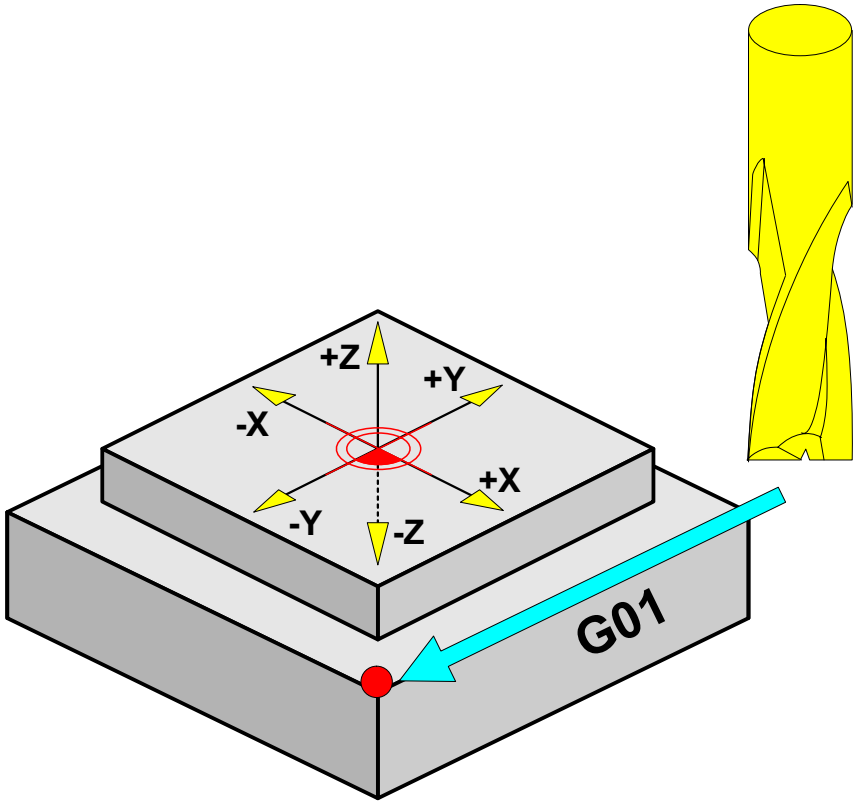

```
N1234 G01 X25 Y-25 LF mm
```

```
N1234 G01 X1 Y-1 LF inch
```

G02

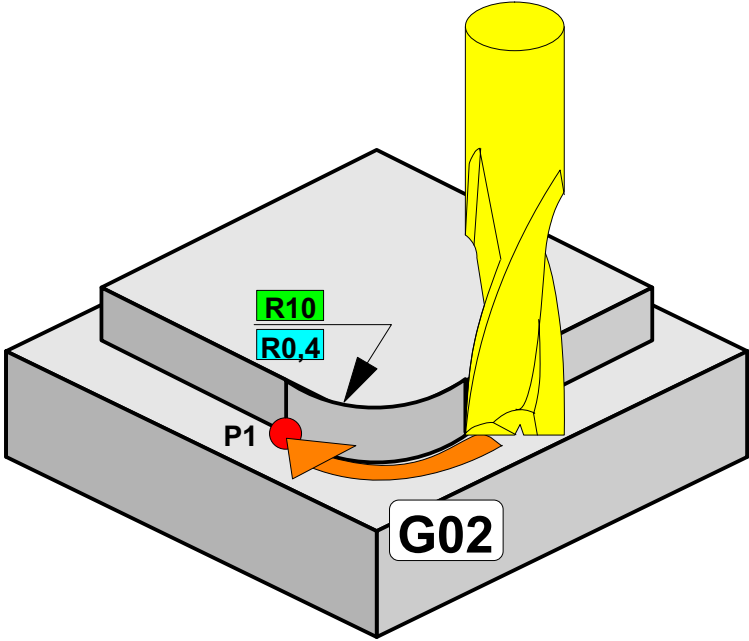

```
N1234 G02 X... Y... R10 LF mm
```

```
N1234 G02 X... Y... R0.4 LF inch
```

G03

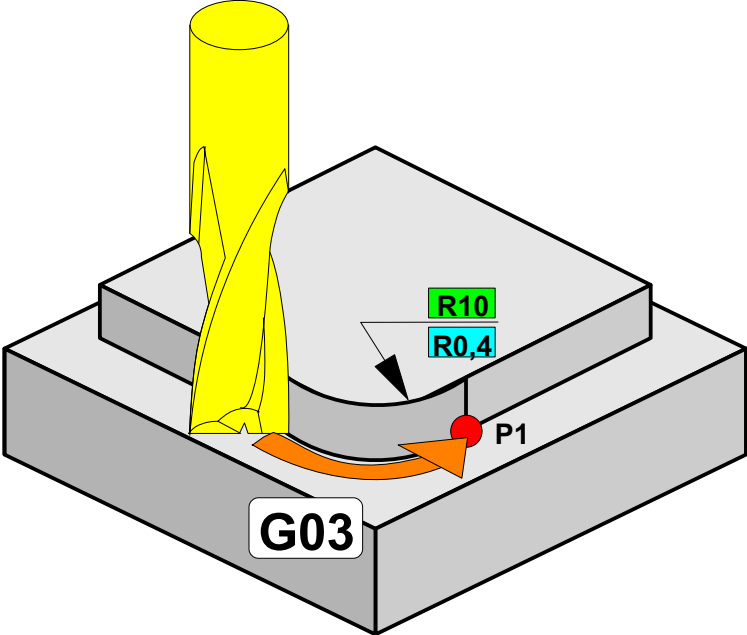

```
N1234 G03 X... Y... R10 LF mm
```

```
N1234 G03 X... Y... R0.4 LF inch
```

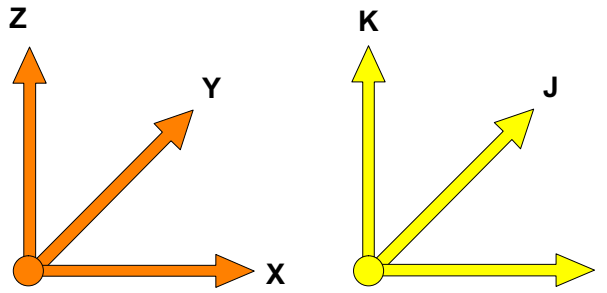

G02

G03

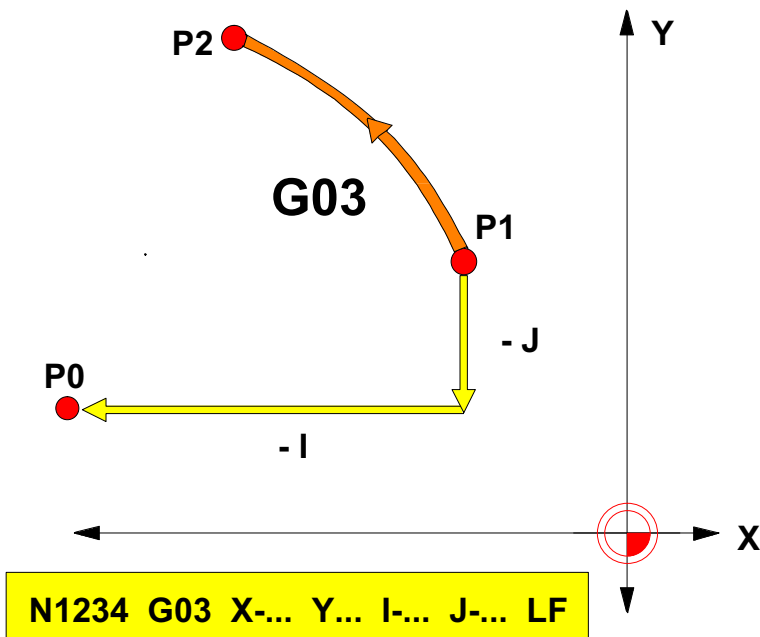
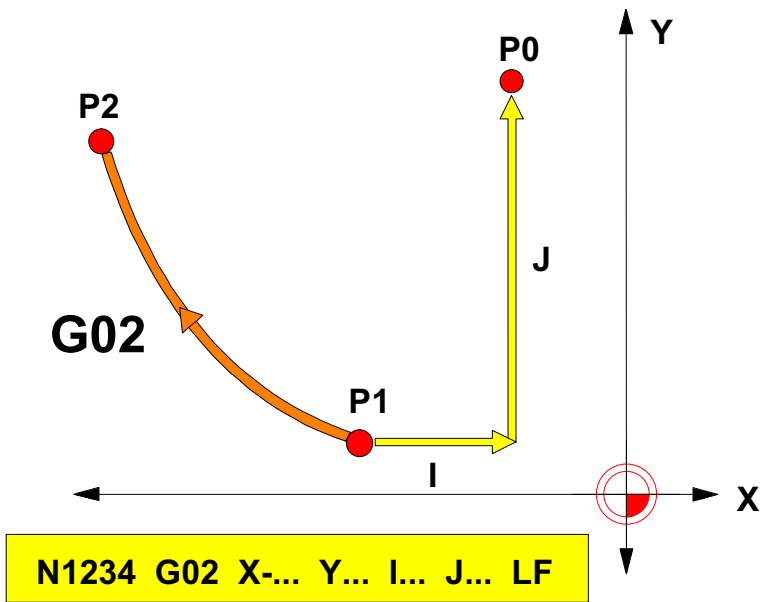

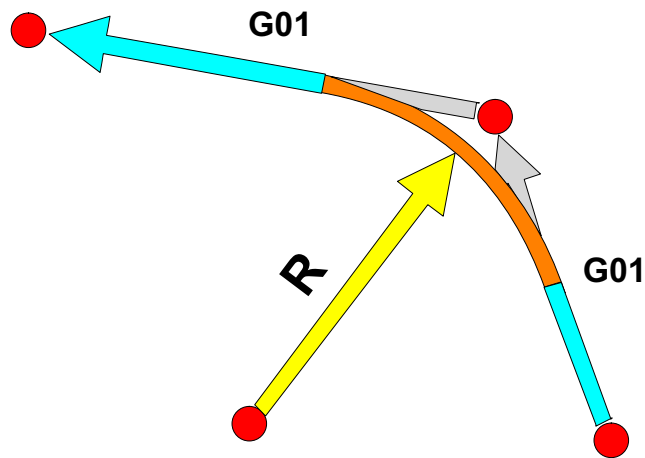

```
N0042 G01 X... Y... R... LF
```

```
N0043 G01 X... Y... LF
```

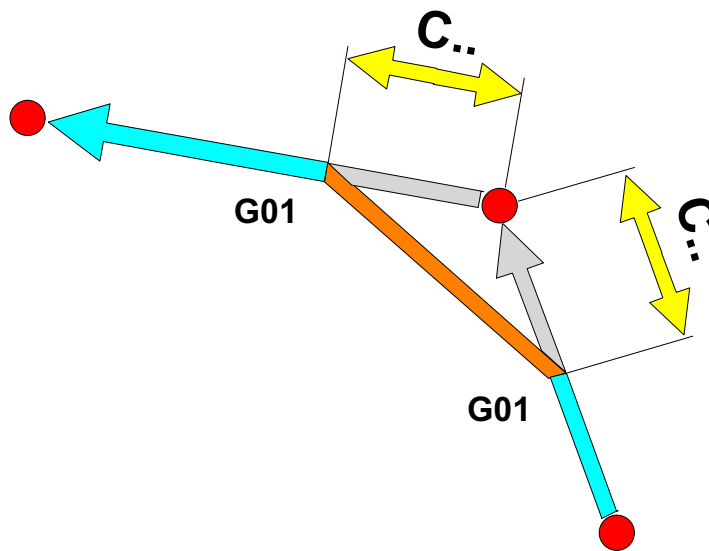

```
N0042 G01 X... Y... C... LF
```

```
N0043 G01 X... Y... LF
```

G04

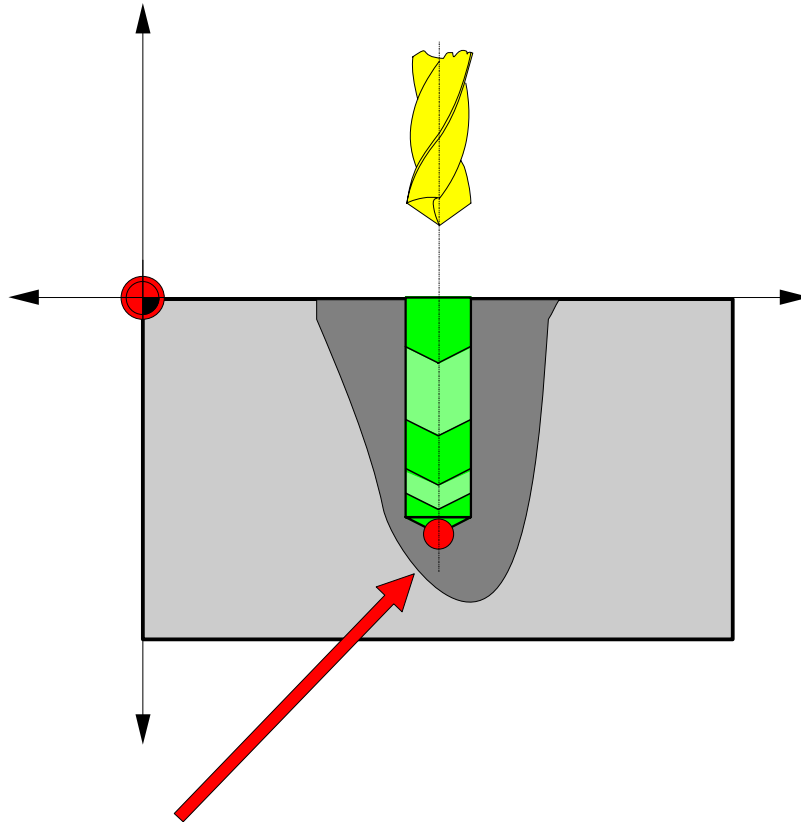

N1234 G04 X... LF

(sec.)



N1234 G04 P... LF

(msec.)

G15

G16

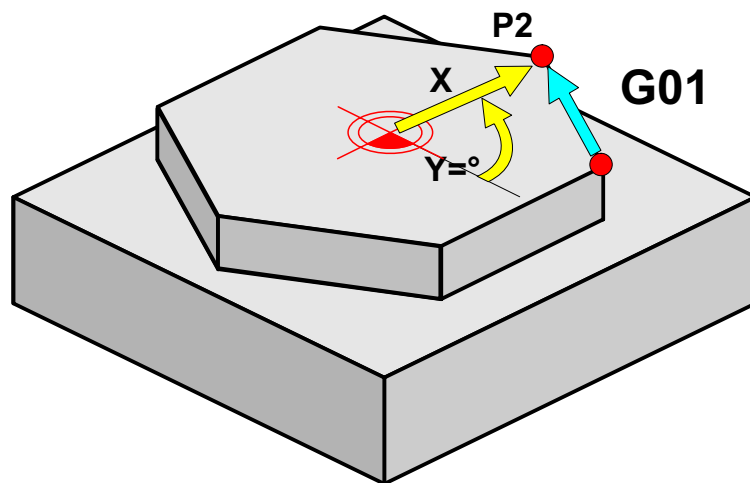
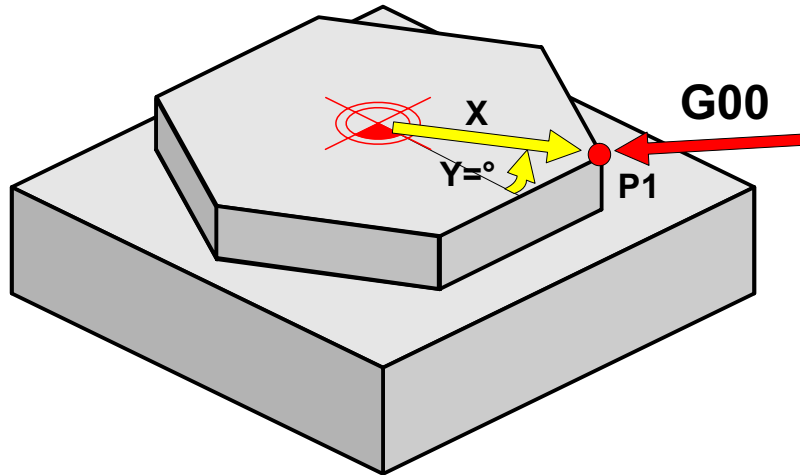

N1234 G16

N1234 G00 X... Y...° (P1)

N1234 G01 X... Y...° (P2)

N1234 G15

G17

G18

G19

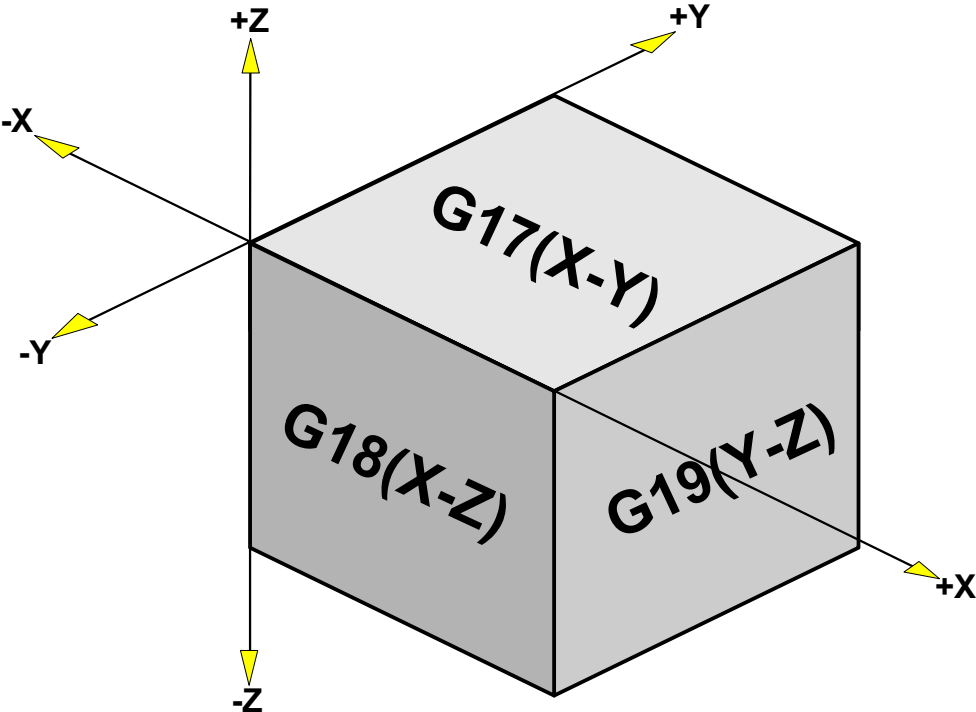

G33

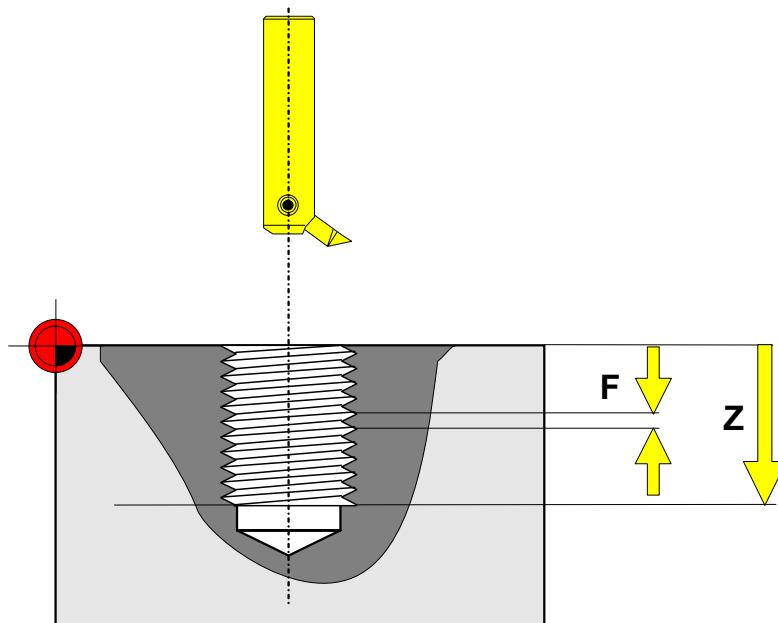

```
N1234 G33 Z ... F ...  
N1234 G01 .....
```

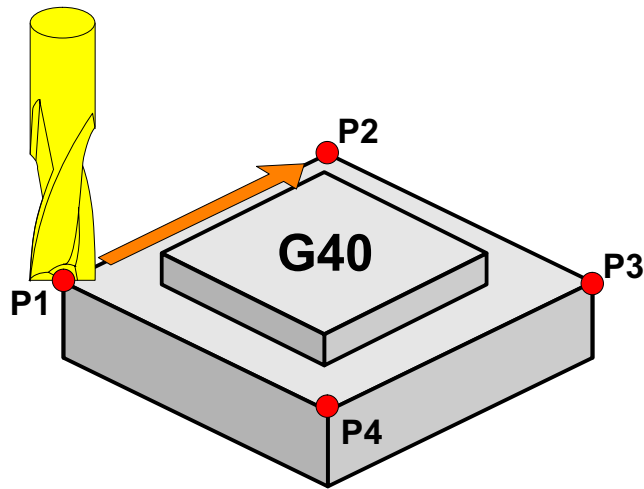

G40

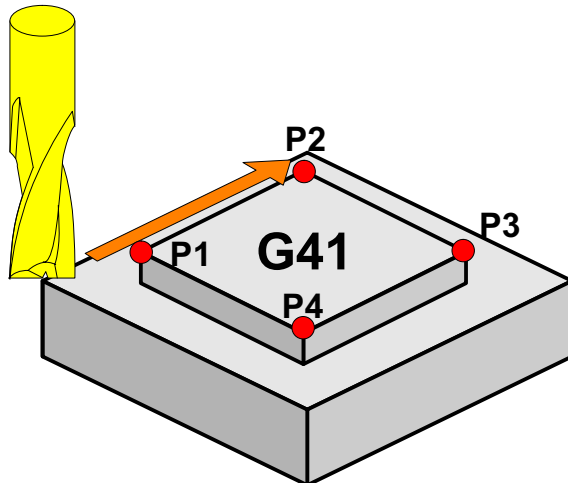

G41

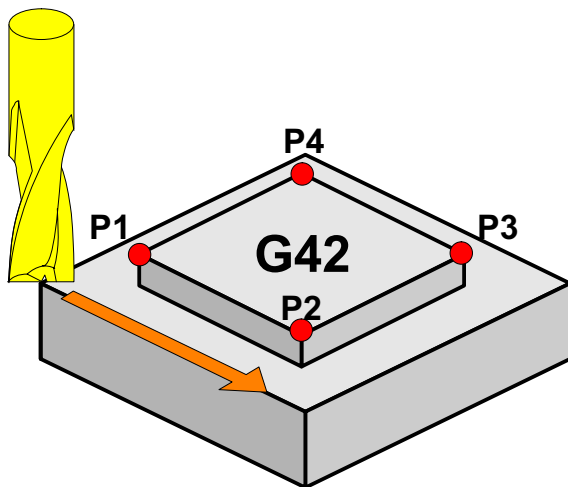

G42

G50

G51

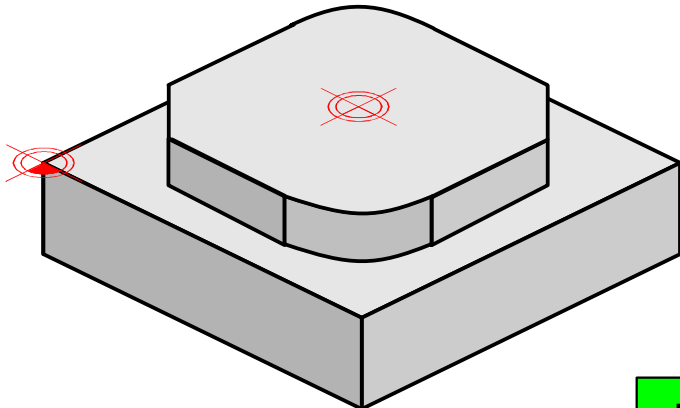
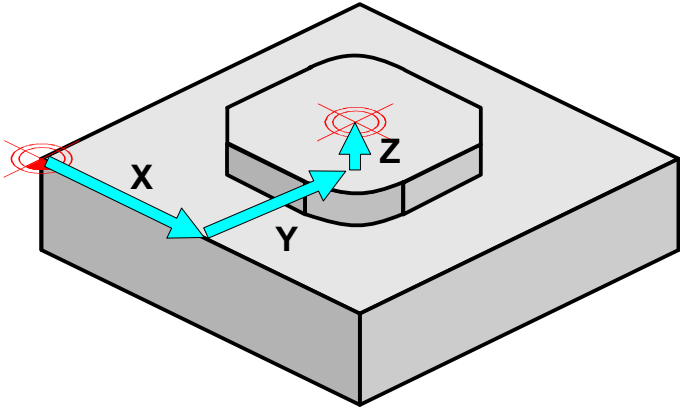

I, J, K	M / S
1000	1 : 1
2000	1 : 2
.....

```
N1234 X... Y... Z... I1500 J1500 K1500
```

G50

G51

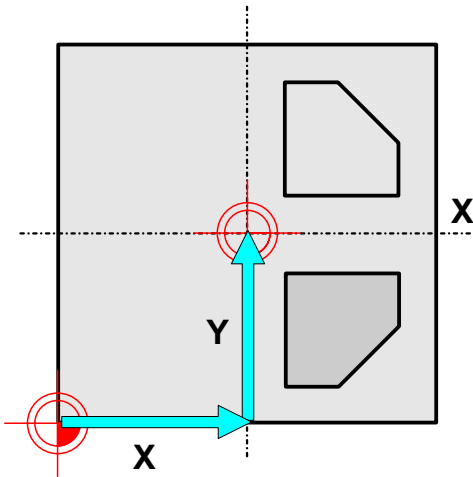

N1234 G51 X... Y... J-1000

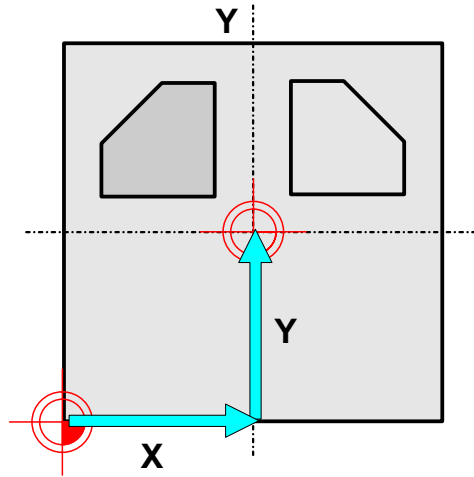

N1234 G51 X... Y... I-1000

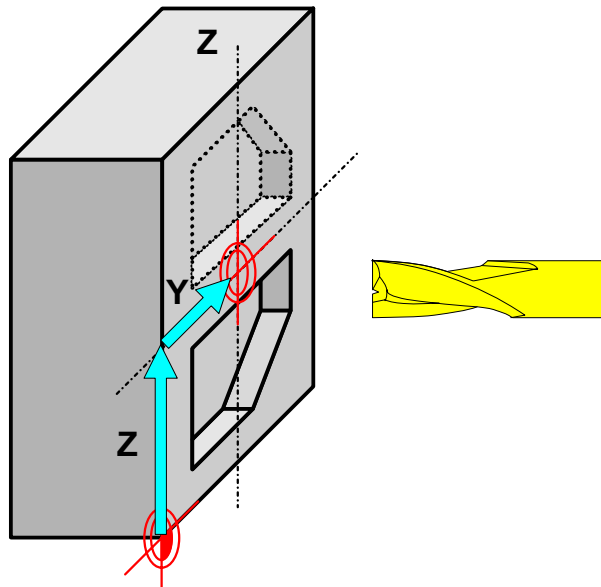

N1234 G51 Y... Z... K-1000

G09

G61

G64

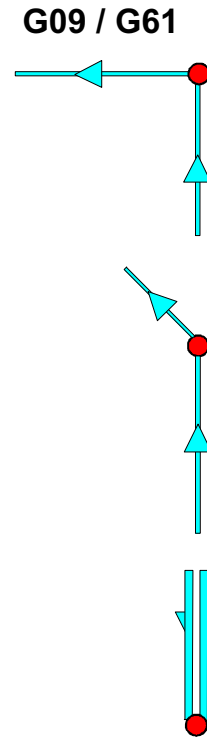
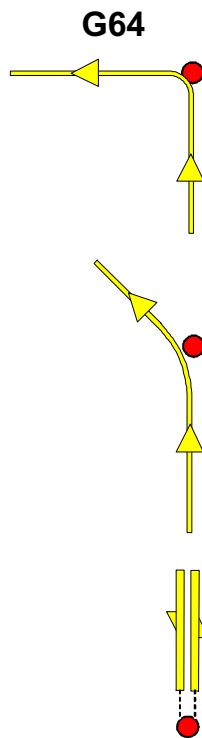
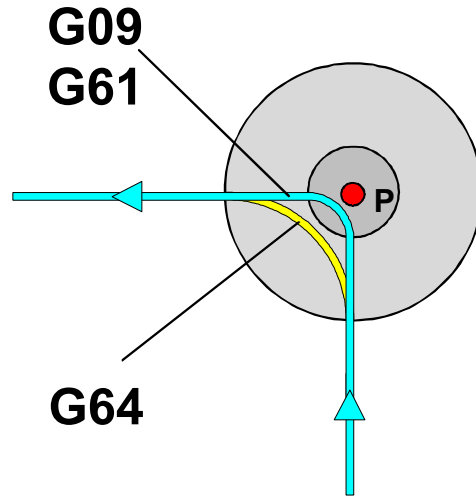

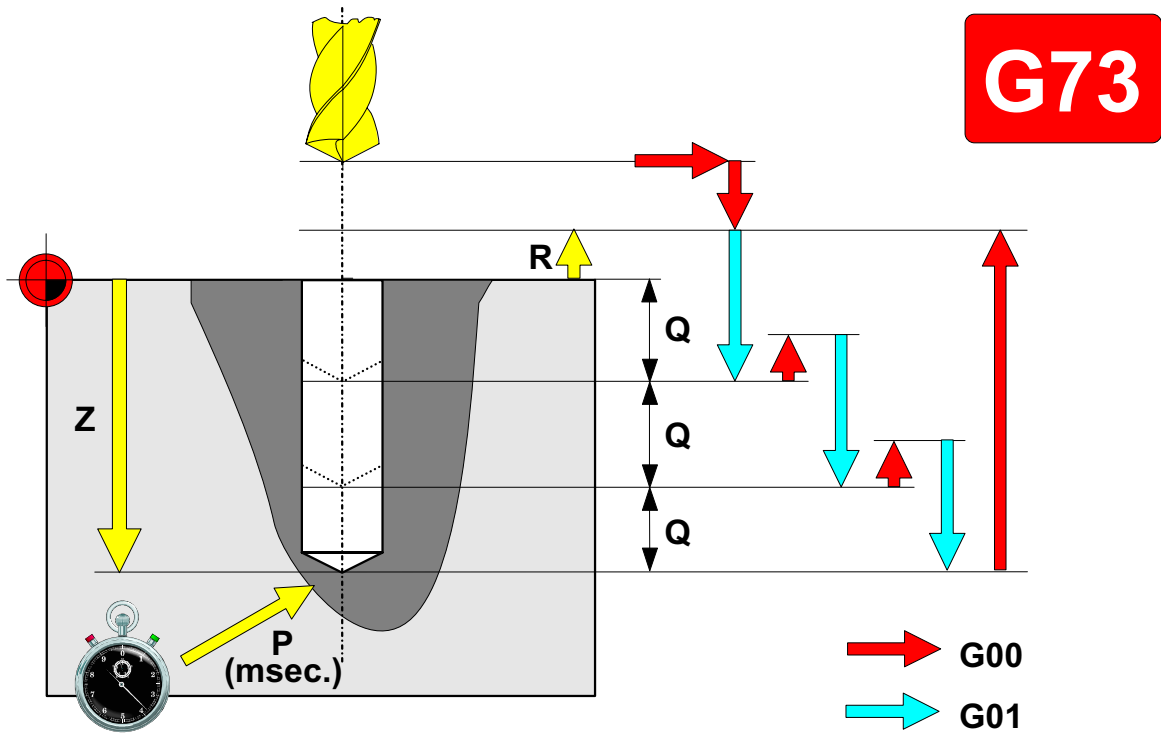

N1234 G73 X... Y... Z... R... P... Q... F...

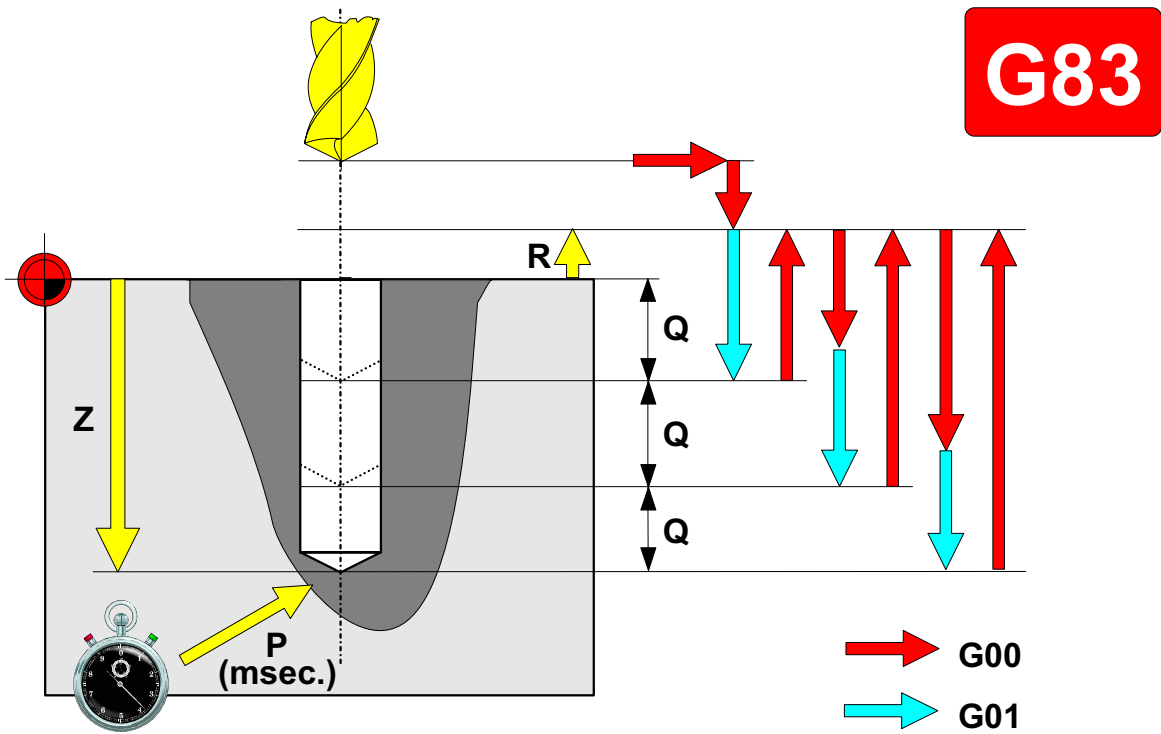

N1234 G83 X... Y... Z... R... P... Q... F...

G74

G84

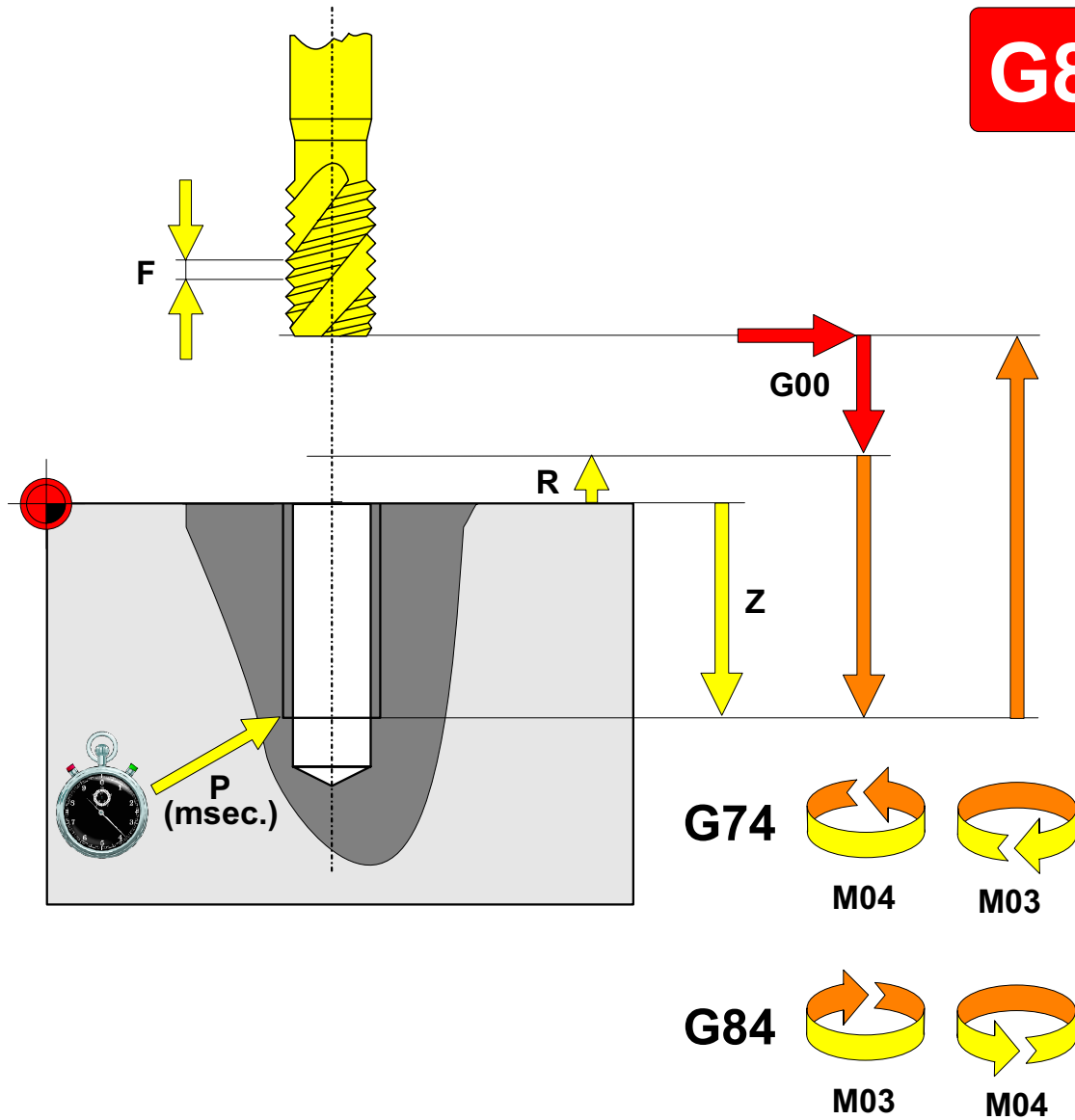

N1234 G74 X... Y... Z... R... F... P ...

N1234 G74 X... Y... Z... R... F... P ...

G81

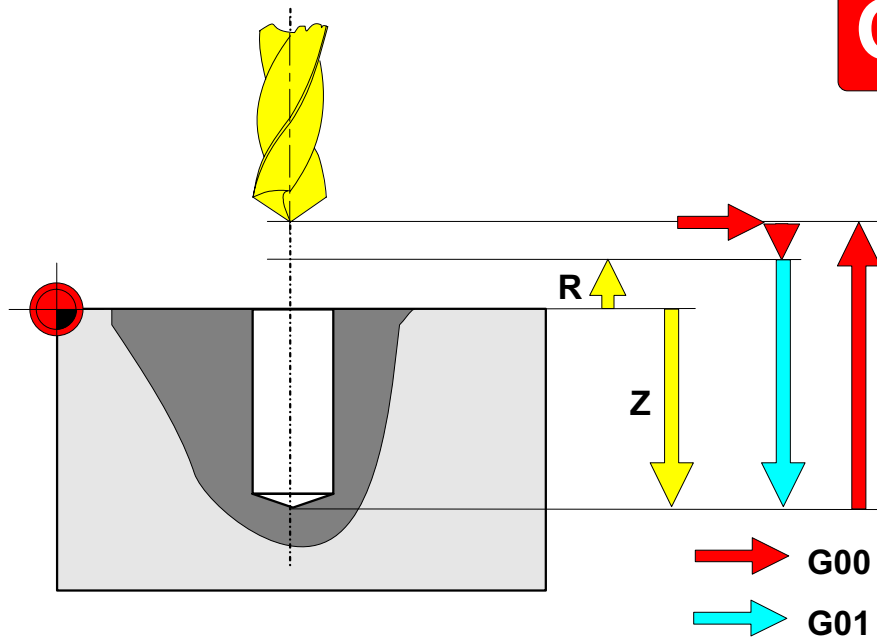

N1234 G81 X... Y... Z... R... F...

G82

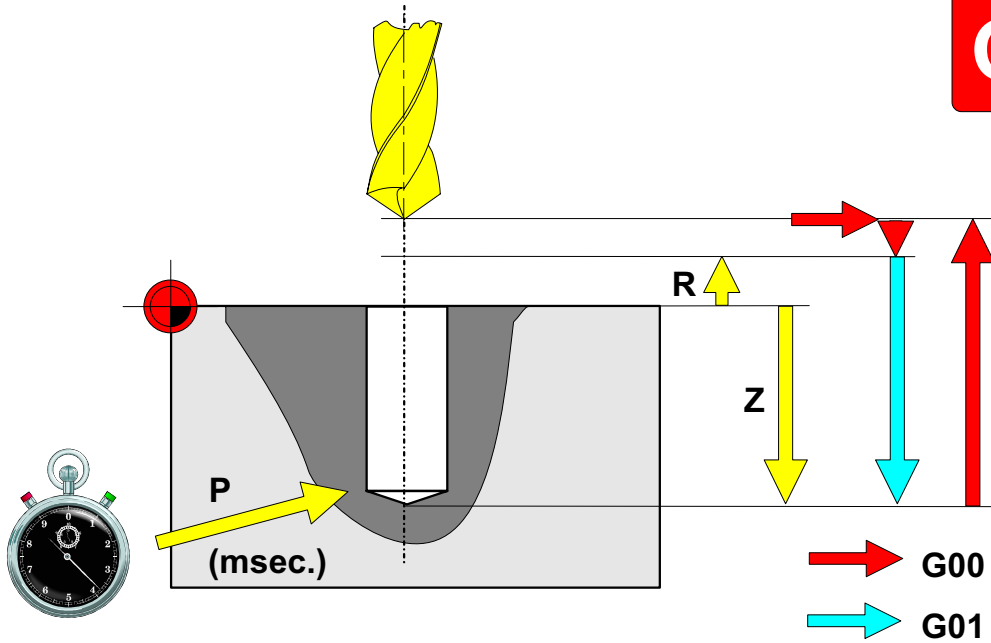

N1234 G81 X... Y... Z... R... P... F...

G85

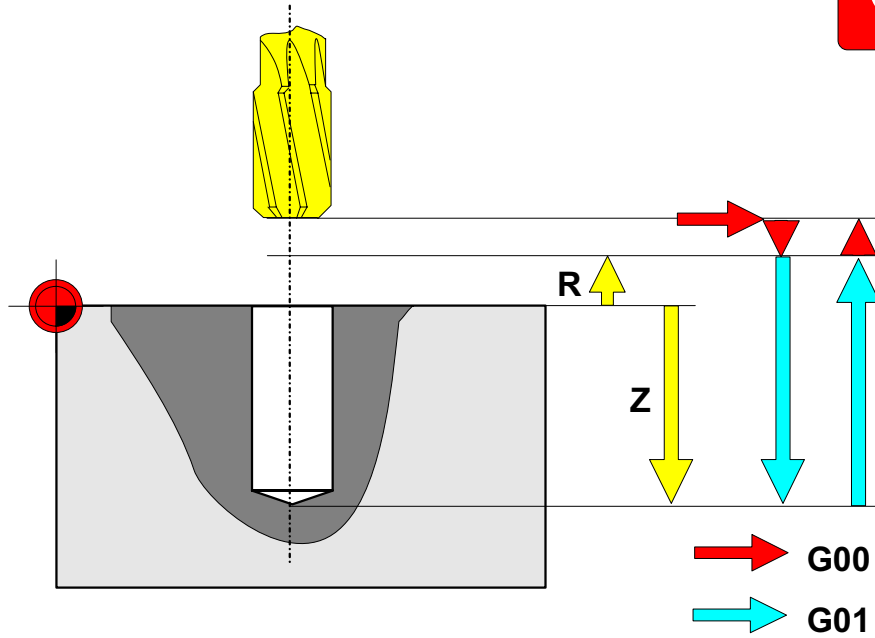

```
N1234 G85 X... Y... Z... R... F...
```

G89

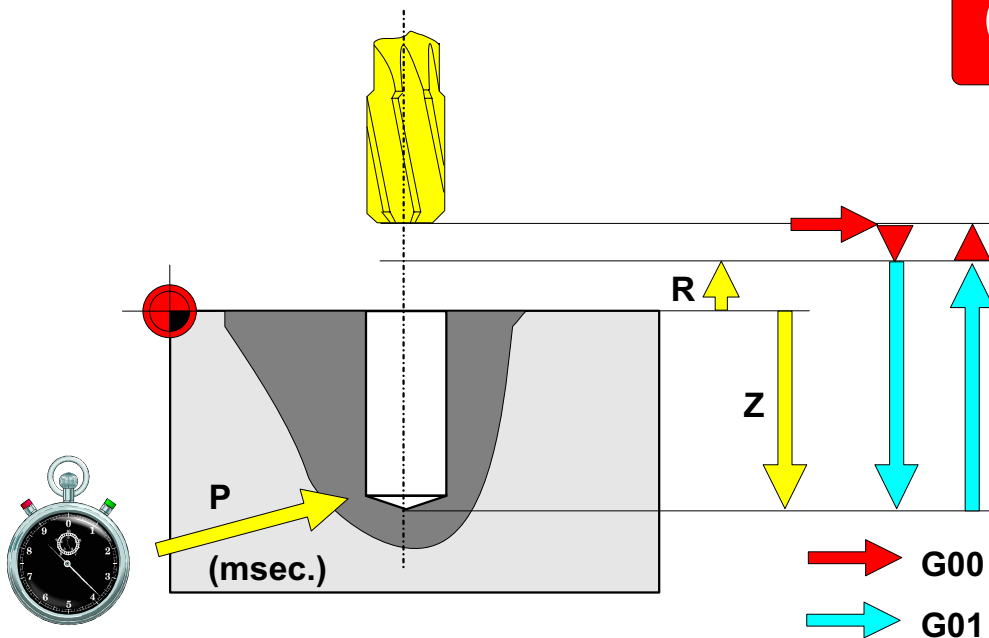

```
N1234 G89 X... Y... Z... R... P... F...
```

G86

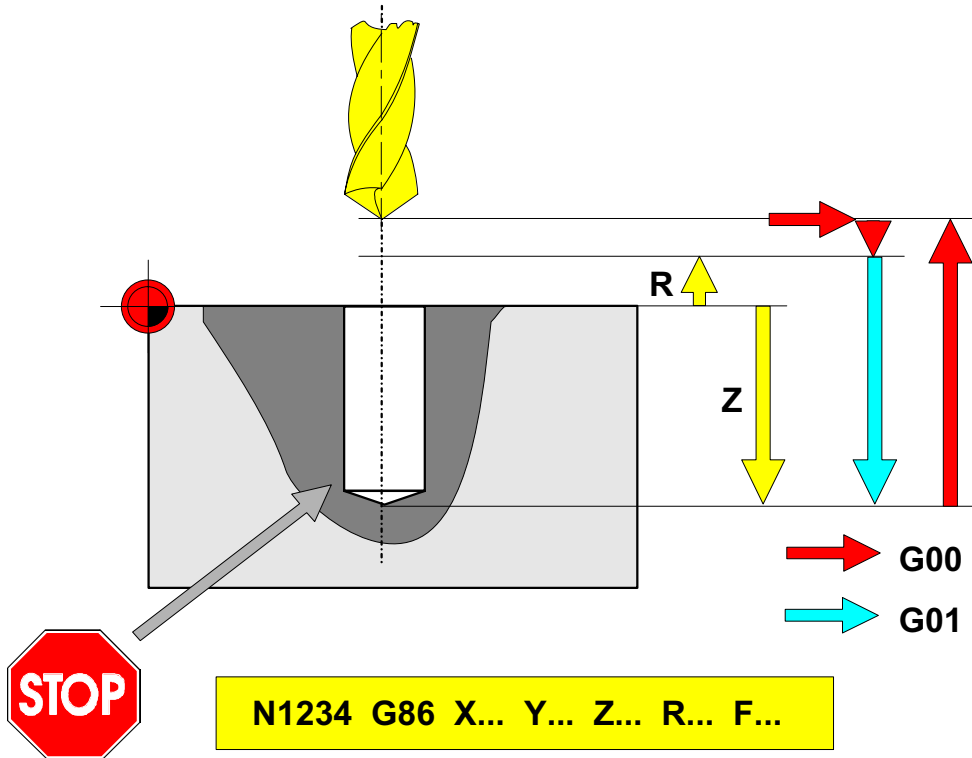

G88

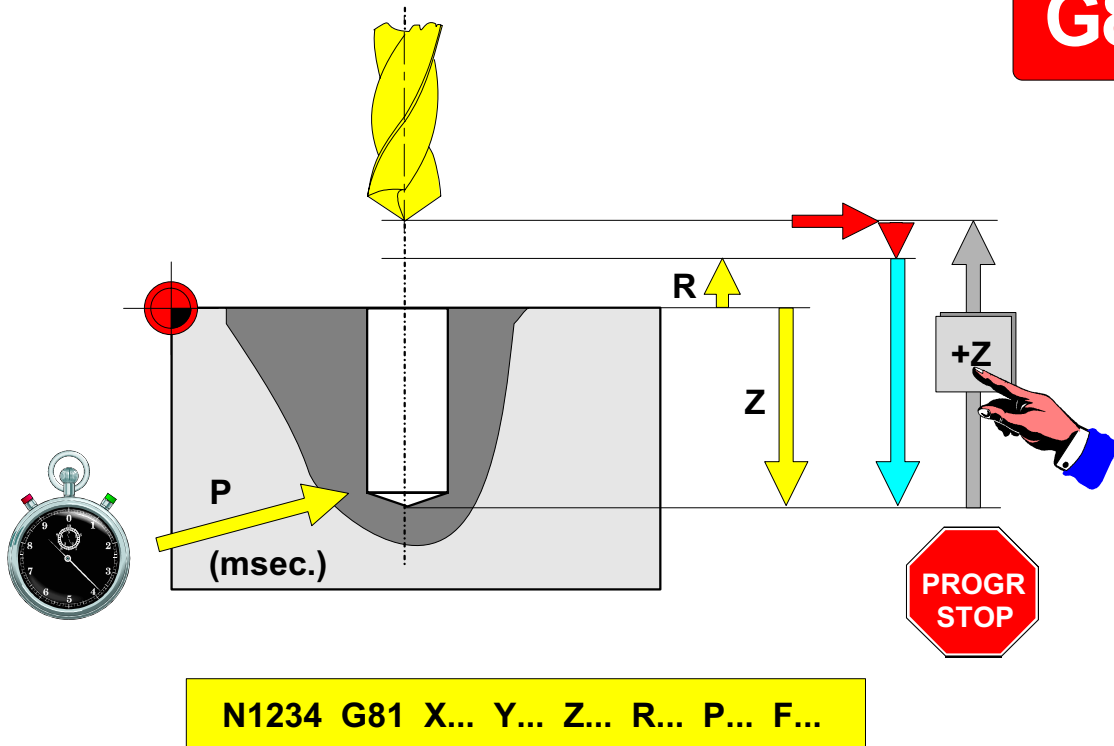

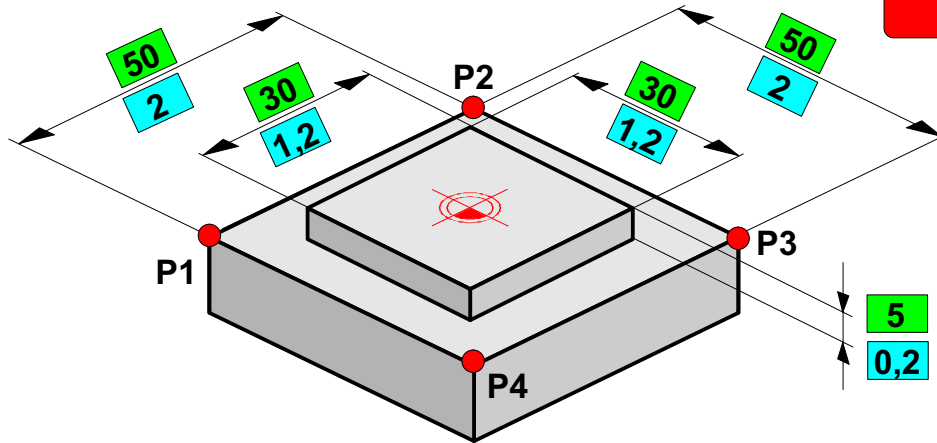
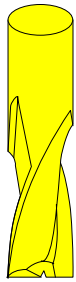

G90

```

N0100 G01 X-25 Y-25 Z-5 LF
N0105 X-25 Y25 LF
N0110 X25 Y25 LF
N0115 X25 Y-25 LF
N0120 X-25 Y-25 LF
    
```

mm

```

N0100 G01 X-1 Y-1 Z-0.2 LF
N0105 X-1 Y1 LF
N0110 X1 Y1 LF
N0115 X1 Y-1 LF
N0120 X-1 Y-1 LF
    
```

Inch

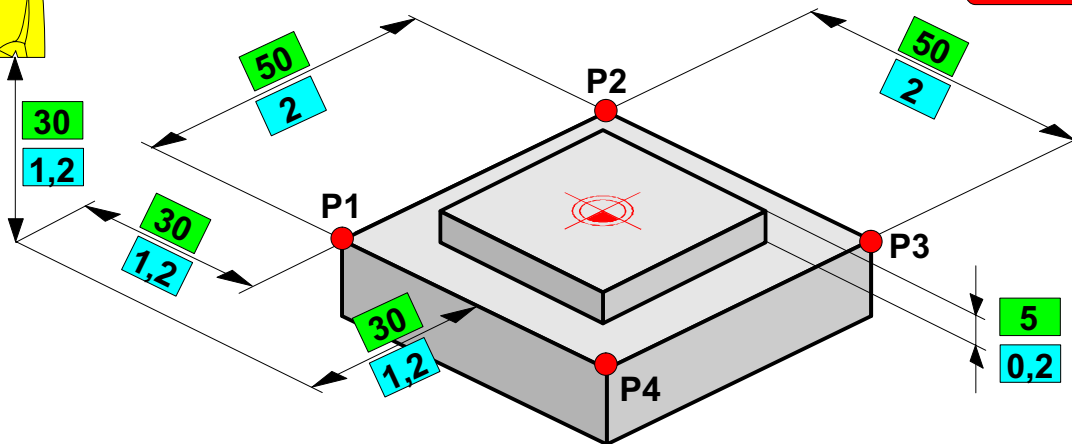
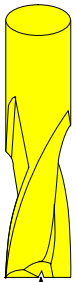

G91

```

N0100 G01 X30 Y30 Z-30 LF
N0105 X0 Y50 LF
N0110 X50 Y0 LF
N0115 X0 Y-50 LF
N0120 X-50 Y0 LF
    
```

mm

```

N0100 G01 X1.2 Y1.2 Z-1.2 LF
N0105 X0 Y2 LF
N0110 X2 Y0 LF
N0115 X0 Y-2 LF
N0120 X-2 Y0 LF
    
```

Inch

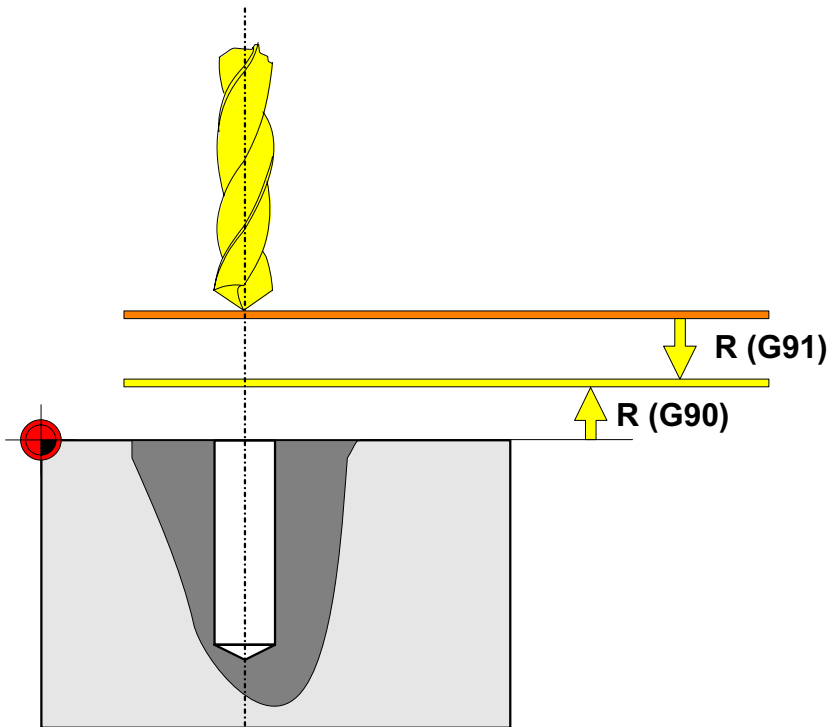

G98

G99

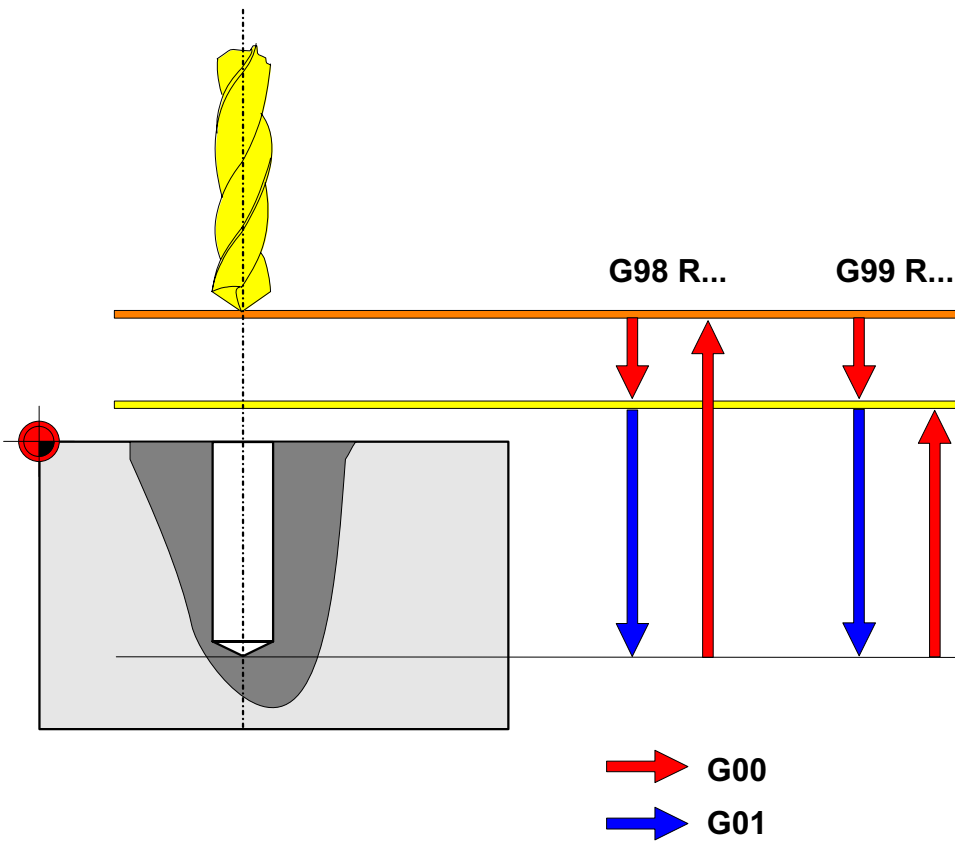

 **G00**

 **G01**

M98

M99

